

OPERATING, MAINTENANCE & PARTS MANUAL

MANUALLY OPERATED LEVER HOIST

CM[®] PULLER

Before installing hoist, fill in the information below.

Model Number _____

Serial No. _____

Purchase Date _____

Rated Load _____

RATED LOADS 3/4, 1-1/2, 3 AND 6 TONS (750, 1500, 3000 AND 6000 KG.)

**Follow all instructions and warnings for inspecting,
maintaining and operating this trolley.**

The use of any hoist presents some risk of personal injury or property damage. That risk is greatly increased if proper instructions and warnings are not followed. Before using this hoist, each operator should become thoroughly familiar with all warnings, instructions and recommendations in this manual. Retain this manual for future reference and use.

Retain this manual for future reference and use.

Forward this manual to the trolley operator. Failure to operate equipment as directed in manual may cause injury.



CM HOIST PARTS AND SERVICES ARE AVAILABLE IN THE UNITED STATES AND IN CANADA

As a CM Hoist and Trolley user you are assured of reliable repair and parts services through a network of Master Parts Depots and Service Centers that are strategically located in the United States and Canada. These facilities have been selected on the basis of their demonstrated ability to handle all parts and repair requirements promptly and efficiently. To quickly obtain the name of the Master Parts Depot or Service Center located nearest you, call (314) 869-7200.

LAS PIEZAS Y REPARACIONES DE LOS POLIPASTOS DE CM ESTÁN ASEGURADAS EN ESTADOS UNIDOS Y CANADÁ

Como usuario de un polipasto y carro de CM le aseguramos cualquier reparación o la disponibilidad de cualquier pieza de repuesto a través de una red de almacenes de piezas de repuesto y centros de servicio situados estratégicamente en Estados Unidos y Canadá. Estas instalaciones se han seleccionado en base a su capacidad demostrada en la reparación de equipos y suministro de piezas de repuesto de forma rápida y eficaz. Para obtener la dirección del almacén de piezas de repuesto o del centro de servicio más cercano, llame al teléfono (314) 869-7200.

LE SERVICE DE RÉPARATION ET DE PIÈCES POUR PALANS CM EST DISPONIBLE AUX ÉTATS-UNIS ET AU CANADA

Soyez assurés qu'en temps d'utilisateur de palan et treuil CM, d'un service de réparation et de pièces fiable par l'entremise d'un réseau de Centres de service et de Dépôts de pièces maîtresses qui sont stratégiquement situés aux États-Unis et au Canada. Ces établissements ont été sélectionnés sur une base de leur habileté démontrée à s'occuper promptement et efficacement des besoins de réparation de pièces. Appelez le (314) 869-7200.

WARNING

Improper operation of a hoist can create a potentially hazardous situation which, if not avoided, could result in death, or serious injury. To avoid such a potentially hazardous situation, the operator shall:

1. **NOT** operate a malfunctioning or unusually performing hoist.
2. **NOT** operate the hoist until you have thoroughly read and understood this manual.
3. **NOT** operate a hoist which has been modified without the manufacturer's approval or certification to be in conformity with applicable OSHA regulations.
4. **NOT** lift or pull more than rated load for the hoist.
5. **NOT** use damaged hoist or hoist that is not working properly.
6. **NOT** use hoist with twisted, kinked, damaged, or worn load chain.
7. **NOT** operate with any lever extension (cheater bar).
8. **NOT** attempt to "free chain" the hoist while a load is applied.
9. **NOT** use the hoist to lift, support, or transport people.
10. **NOT** lift loads over people and make sure all personnel remain clear of supported load.
11. **NOT** attempt to lengthen the load chain or repair damaged load chain.
12. Protect the hoists load chain from weld splatter or other damaging contaminants.
13. **NOT** operate a hoist when it is restricted from forming a straight line from hook to hook in the direction of loading.
14. **NOT** use load chain as a sling or wrap load chain around load.
15. **NOT** apply the load to the tip of the hook or to the hook latch.
16. **NOT** apply load unless load chain is properly seated in the chain wheel(s) or sprocket(s).
17. **NOT** apply load if bearing prevents equal loading on all load supporting chains.
18. **NOT** operate beyond the limits of the load chain travel.
19. **NOT** leave load supported by the hoist unattended unless specific precautions have been taken.
20. **NOT** allow the chain or hook to be used as an electrical or welding ground.
21. **NOT** allow the chain or hook to be touched by a live welding electrode.
22. **NOT** remove or obscure the warnings on the hoist.
23. **NOT** operate a hoist which has Not been securely attached to a suitable support.
24. **NOT** operate a hoist unless load slings or other approved single attachments are properly sized and seated in the hook saddle.
25. **NOT** lift loads that are Not balanced and the holding action is Not secure, taking up slack carefully.
26. **NOT** operate a hoist unless all persons are and remain clear of the supported load.
27. Report malfunctions or unusual performances of a hoist, after it has been shut down until repaired.
28. **NOT** operate a hoist on which the safety placards or decals are missing or illegible.
29. Be familiar with operating controls, procedures and warnings.

CAUTION

Improper operation of a hoist can create a potentially hazardous situation which, if not avoided, could result in minor or moderate injury. To avoid such a potentially hazardous situation, the operator shall:

1. Maintain a firm footing or be otherwise secured when operating the hoist.
2. Check brake function by tensioning the hoist prior to each lift or pulling operation.
3. Use hook latches. Latches are to retain slings, chains, etc. under slack conditions only.
4. Make sure the hook latches are closed and not supporting any parts of the load.
5. Make sure the load is free to move and will clear all obstructions.
6. Avoid swinging the load or hook.
7. Avoid lever "fly-back" by keeping a firm grip on the lever until operating stroke is completed and lever is at rest.
8. Inspect the hoist regularly, replace damaged or worn parts, and keep appropriate records of maintenance.
9. Use Columbus McKinnon parts when repairing the unit.
10. Lubricate load chain as recommended in this manual.
11. **NOT** operate except with manual power.
12. **NOT** permit more than one operator to pull on lever at the same time. More than one operator is likely to cause hoist overload.
13. **NOT** allow your attention to be diverted from operating the hoist.
14. **NOT** allow the hoist to be subjected to sharp contact with other hoists, structures, or objects through misuse.
15. **NOT** adjust or repair the hoist unless qualified to perform such adjustments or repairs.

The hoists are intended for general industrial use for moving loads within their load ratings. Prior to installation and operation, the user should review the application for abnormal environmental or handling conditions.

GENERAL SAFETY INFORMATION

ADVERSE ENVIRONMENTAL CONDITIONS

Do not use the hoists in areas containing flammable vapors, liquids, gasses or any combustible dust or fibers. Do not use the hoist in highly corrosive, abrasive, wet environments.

MOVING HAZARDOUS LOADS

The hoists are not recommended for lifting materials that could cause widespread damage if dropped. The lifting or moving of materials that could explode or cause chemical or radioactive contamination requires fail-safe, redundant supporting devices that are not incorporated into these hoists.

HOIST SAFETY IS UP TO YOU...

⚠ WARNING

DO NOT LIFT MORE THAN RATED LOAD.

CHOOSE THE RIGHT HOIST FOR THE JOB...

Choose a Puller with the capacity for the job. Know the capacities of your hoists and the weight of your loads.

Then match them.

The application, the size and type of load, the attachments to be used and the period of use must also be taken into consideration in selecting the right hoist for the job.

Remember the Puller was designed to ease our burden and carelessness not only endangers the operator but in many cases, a valuable load.



⚠ WARNING

DO NOT OPERATE DAMAGED OR MALFUNCTIONING UNIT.

DO NOT OPERATE WITH TWISTED, KINKED, OR DAMAGED CHAIN.

INSPECT

All Pullers should be visually inspected before use, in addition to regular, periodic maintenance inspections.

Inspect hoists for operation warning notices and legibility.

Deficiencies should be noted and brought to the attention of supervisors. Be sure defective Pullers are tagged and taken out of service until repairs are made.



Under no circumstances should you operate a malfunctioning hoist.

Check for gouged, twisted, distorted links and foreign material. Do not operate Pullers with twisted, kinked or damaged chain links.



Load chain should be properly lubricated.

Hooks that are bent, worn or whose openings are enlarged beyond normal throat opening should not be used. If latch does not engage throat opening of hook, hoist should be taken out of service.

Chains should be checked for deposits of foreign material which may be carried into the hoist mechanism.

Check brake for evidence of slippage under load.

⚠ WARNING

DO NOT PULL AT AN ANGLE. BE SURE PULLER AND LOAD ARE IN A STRAIGHT LINE.

DO NOT USE UNLESS FRAME AND CHAIN FORM A STRAIGHT LINE BETWEEN HOOKS.

DO NOT USE IF FRAME IS IN CONTACT WITH ANY OBJECT.

DO NOT USE LOAD CHAIN AS A SLING.

DO NOT USE AN EXTENSION ON THE LEVER.

USE HOIST PROPERLY

Be sure the Puller is solidly held in the uppermost part of the support hook arc.

Be sure the Puller and load are in a straight line. Do not use unless frame and chain form a straight line between hooks.

Be sure load is hooked securely. Do not tip load the hook. Do not load hook latch. Hook latch is to prevent detachment of load under slack chain conditions only.

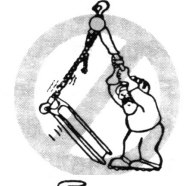
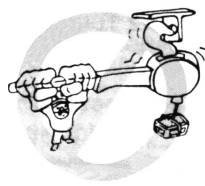

Do not operate with Puller Frame resting against any object. Apply the load gently. Do not jerk it.

Never use an extension on the lever! You're dangerously overloading the Puller if you exceed the rated lever pull or if you have to use a lever extension to lift or pull a load.

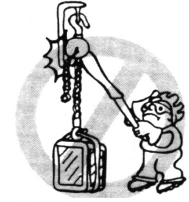

PRACTICE CAUTION ALWAYS

Do not lift co-workers with a Puller.

Make sure everyone is clear of the load when you apply tension.

Do not remove or obscure operational warning notices.



⚠ WARNING

DO NOT LIFT PEOPLE OR LOADS OVER PEOPLE

OPERATOR SERVICE

CLEANING

Pullers should be kept clean and free of dust, dirt, moisture, etc., which will in any way affect the operation or safety of the equipment.

LUBRICATION

Chain should be properly lubricated.

AFTER REPAIRS

Carefully operate the hoist before returning it to full service.



VIOLATIONS OF ANY OF THE WARNINGS LISTED MAY RESULT IN SERIOUS PERSONAL INJURY TO THE OPERATOR OR NEARBY PERSONNEL BY NATURE OF RELEASED LOAD OR BROKEN HOIST COMPONENTS.

FOREWORD

This manual contains important information to help you properly install, operate and maintain the CM® Series 640 Puller Lever Hoist for maximum performance, economy and safety.

Please study its contents thoroughly before putting your trolley into operation. By practicing correct operating procedures and by carrying out the recommended preventive maintenance suggestions, you will experience long, dependable and safe service.

After you have completely familiarized yourself with the contents of this manual, we recommend that you carefully file it for future reference.

SAFETY PRECAUTIONS

Operating and Safety Procedures	2
Foreword	3

GENERAL INFORMATION

Specifications	4
CM Repair/Replacement Policy	4
Load Limiter	4
Anchor Sling	5
Load Sentry	5

INSTALLATION

Unpacking Information	5
Installation	5

OPERATING INSTRUCTIONS

General	6
---------------	---

INSPECTION

General	7
Frequency of Inspection	8
Hook Inspection	9
Chain Inspection	9
Chain Lubrication	10

MAINTENANCE

Lubrication	10
Exterior Finish	10
Preventive Maintenance	10
Disassembly	10
Assembly	10
Reeving	11

REPAIR PARTS

Ordering Information	13
Recommended Spare Parts	13
Touch-up Paint for the Puller	20
Cutting Chain	20
Testing	20

TROUBLESHOOTING

General	21
---------------	----

LOAD LIMITER

General	22
---------------	----

LIST OF TABLES

TABLE	DESCRIPTION	PAGE
1	Specifications	4
2	Hook Throat Opening	9

LIST OF ILLUSTRATIONS

FIG.	DESCRIPTION	PAGE
1	Optional Load Limiter	4
2	Anchor Sling	5
3	Upper or Lower Latch Type Hook	5
4	Load Sentry	5
5	Pulling on an Angle	5
6	Horizontal Pulling	5
7	Vertical Pulling	5
8	Angle Pulling	6
9	CM Puller Nomenclature	6
10	Hook Throat Opening	9
11	Chain Inspection	9
12	Gaging Load Chain Wear	9
13	Ratchet and Ratchet Plunger Assembly	10
14	Brake Parts	11
15	Brake Nut Cotter Pin Assembly	11
16	Lever Assembly	11
17	Chain Assembly - Hook End, 3/4 Ton	11
18	Chain Assembly - Hook End, 1-1/2 Ton	12
19	Reeving 3-Ton	12
20	Reeving 6-Ton	12
21	Cutting Chain by Nicking	20
22	Cutting Chain with a Bolt Cutter	20
23	Load Limiter	22

GENERAL INFORMATION

SPECIFICATIONS

CM® Puller Manually Operated Chain Hoist is a highly versatile tool that can be used to efficiently pull, lift, drag, or stretch. The load chain is strong and durable CM® Hoistaloy®. The frame and lever are made of lightweight aluminum alloy. An automatic brake supplies positive load control and will suspend the load at any point. Latch type hooks are standard on all capacities. The Pullers have lever lengths of 23 inches (584 mm).

The standard lift on all Pullers is 5 feet (1.5 mm). However, Pullers with longer lift can be supplied on a special, per order basis.

CM®'s Load Limiter and Load Sentry are optional items for Pullers with standard levers. The optional CM® Anchor Sling is available for the 3/4 and 1-1/2 ton Pullers with standard or short lever. CM®'s Latchlok upper and lower hooks are optional items for all Pullers.



Figure 1 - Optional Load Limiter

CM® REPAIR/REPLACEMENT POLICY

All Columbus McKinnon (CM®) Pullers are thoroughly inspected and performance tested prior to shipment. If any properly maintained Puller develops a performance problem due to a material or workmanship defect, as verified by CM®, repair or replacement of the unit will be made to the original purchaser without charge. This repair/replacement policy applies only to Pullers installed, maintained and operated as outlined in this manual, and specifically excludes parts subject to normal wear, abuse, improper installation, improper or inadequate maintenance, hostile environment effects, and unauthorized repairs/modifications.

We reserve the right to change materials or design if, in our opinion, such changes will improve our product. Abuse, repair by an unauthorized person, or use of non CM® replacement parts voids the guarantee and could lead to dangerous operation. For full Terms of Sale, see Sales Order Acknowledgment. Also, refer to the back cover for Limitations of Warranties, Remedies and Damages and, Indemnification's and Safe Operation.

LOAD LIMITER

The Load Limiter is a friction device that is designed and factory calibrated to prevent the lifting of excessive overloads with 3/4, 1-1/2, 3 and 6 Ton Pullers that have standard levers. Excessive overload is indicated by lever movement without the corresponding movement of the lower hook block or load when the unit is operated in the "Up" direction. Should overload be evident, immediately switch the trigger to "Down" direction and operate the lever to remove the excess load from the unit. The reduction of the load to rated capacity or less will result in automatic restoration of normal operation.

Load Limiter assures positive warning of overload condition. You may order the Load Limiter as part of your new Puller or in kit form for easy installation in units with standard levers now in use. The Load Limiter is designed for use on the CM® Puller only. For additional information on the Load Limiter refer to page 22.

Table 1 – Specifications

Capacity		Lift		Reeving	Product Code	Weight*		Product Code w/ Load Limiter	Weight*		Product Code w/ Load Sentry	Weight*		Pull Force		Handle Length		Headroom	
ton	kg	ft	m		Standard	lb	kg		lb	kg		lb	kg	lb	kg	in	mm	in	mm
3/4	750	0	0	1	4074	14	6.4	4203	14	6.4	4073	14	6.4	58	26	21.25	539.75	10.75	273.05
		5	1.5		4043	16	7.3	4193	16	7.3	4001	16	7.3						
		10	3		4060	20	9.1	4257	20	9.1	-	20	9.1						
		15	4.5		4250	23	10.4	4258	23	10.4	-	23	10.4						
		20	6		4061	36	16.3	4259	36	16.3	-	36	16.3						
1-1/2	1500	0	0	1	4076	21	9.5	4205	21	9.5	4075	21	9.5	83	38	21.25	539.75	14.25	361.95
		5	1.5		4045	26	11.8	4195	26	11.8	4002	26	11.8						
		10	3		4062	31	14.1	4560	31	14.1	-	31	14.1						
		15	4.5		4251	36	16.3	4261	36	16.3	-	36	16.3						
		20	6		4063	40	18.1	4262	40	18.1	-	40	18.1						
3	3000	0	0	2	4078	27	12.2	4207	27	12.2	4077	27	12.2	95	43	21.25	539.75	16.94	430.276
		5	1.5		4047	38	17.2	4197	38	17.2	4003	38	17.2						
		10	3		4065	47	21.3	4263	47	21.3	-	47	21.3						
		15	4.5		4252	56	25.4	4266	56	25.4	-	56	25.4						
		20	6		4066	65	29.5	4267	65	29.5	-	65	29.5						
6	6000	0	0	4	4079	54	24.5	4210	54	24.5	-	54	24.5	96	44	21.25	539.75	21.38	543.052
		5	1.5		4050	73	33.1	4200	73	33.1	4005	73	33.1						
		10	3		4051	91	41.3	4268	91	41.3	-	91	41.3						
		15	4.5		4253	108	49.0	4269	108	49.0	-	108	49.0						
		20	6		4256	128	58.1	4270	128	58.1	-	128	58.1						

*Listed weight is approximate. Contact factory if specific weight is required.

ANCHOR SLING

(3/4 and 1-1/2 Ton Units)

Anchor Sling is an upper hook extender that simplifies attachment when application or space limitation makes it impossible to pull in a straight line from hook to hook. A swiveling hook block is securely anchored to the tool housing and the upper hook swivels through a full 360. Anchor Sling may be ordered as a feature of your new CM® Puller or in kit form for simple installation on units now in use.



Figure 2 - Anchor Sling

The CM® Puller is supplied with Latch-type upper and lower hooks as standard. Latchlok hooks are an available option.



Figure 3 - Upper or Lower Latch Type Hook

LOAD SENTRY

(3/4 thru 6 Ton Units with Standard Levers)

⚠ WARNING
Grip deflection denotes dangerous overloading.
TO AVOID INJURY: DO NOT CONTINUE OPERATION AFTER LEVER FORCES WHICH CAUSE GRIP DEFLECTION.

The Load Sentry is an overload indicating device. When dangerous overloads, in excess of rated capacity, are applied to the unit, the Load Sentry grip gradually deflects with increasing overloads to warn of the danger involved.

Since calibration is permanent and is pre-set by the factory, the user should not tamper with the calibration nor should repair be made by the user.

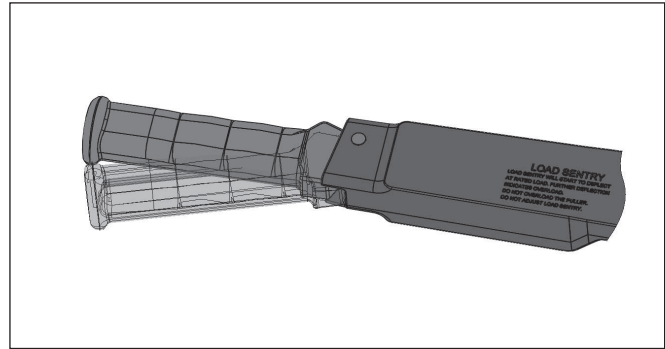

Figure 4 - Load Sentry

Load Sentry assures positive warning of overload condition. You may order Load Sentry as part of your new Puller or in kit form for easy installation in units now in use. The CM® Load Sentry is designed for use on the CM® Puller only.

INSTALLATION

UNPACKING INFORMATION

After removing the Puller from the carton, check to be sure there has been no damage in shipment. If shipping damage has occurred, refer to the packing list envelope on the carton for claim procedure. Before cutting the chain ties on multiple-reeved units, be sure that all strands of chain are straight with no twist (due to a capsized hook block). If length of lift is to be modified, follow disassembly and assembly instructions for correct procedure. Make certain that the hook side of the chain is on the side of the tool marked "lower hook side" on the chain guide.

INSTALLATION

The Puller can be used in any position provided it is rigged to pull in a straight line from hook to hook.

Fig. 5-7 show proper operation for common applications. It is important that the frame is free to swivel on the upper hook. Under no condition should the frame be allowed to touch the load or bear on any support when in use as this might cause bending of the hook or frame and possible failure. When operating in limited areas it is recommended that lifting attachments or slings be used to keep the frame and lever from being obstructed.

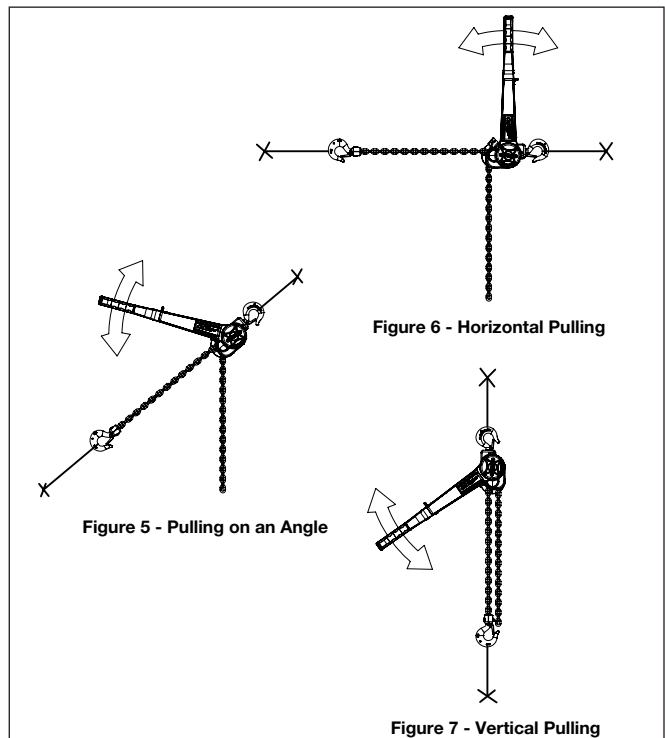

⚠ WARNING

If the unit is not rigged in a straight line hook to hook manner, and if the frame is not free to swivel, lever pull may break frame and cause physical injury and loss of load.

TO AVOID INJURY:

Rig the unit in a straight line hook to hook manner and keep frame free to swivel - see Fig. 8.

OPERATING INSTRUCTIONS

⚠ WARNING

If not used as directed, puller may cause injury.

TO AVOID INJURY:

Use only as directed below.

⚠ WARNING

Pulling out or turning the ratchet plunger with a load attached will allow the load to release and may cause injury.

TO AVOID INJURY:

Never pull or turn ratchet plunger when the puller is under load.

Free Chaining - In this mode brake and lever are disengaged to allow chain to be pulled through the Puller by hand, for quick and easy attachment to the load.

- To put Puller in free chaining:
1. Be sure unit is not loaded.
 2. Pull out ratchet plunger.
 3. Turn ratchet plunger 1/4 turn left or right.
 4. Turn the lever trigger 1/4 turn from "UP" or "DOWN".

Grasp the Puller by the frame or upper hook and pull on the end ring or lower hook to pull the chain through the unit. **DO NOT** hold the lever when free chaining as this may cause the chain to jam in the unit.

After attaching to the load, turn ratchet plunger 1/4 turn until it snaps into engagement and turn lever trigger to "UP" or "DOWN" for further use.

⚠ WARNING

If the unit is not rigged in a straight line hook to hook manner, and if the frame is not free to swivel, lever pull may break frame and cause physical injury and loss of load.

TO AVOID INJURY:

Rig the unit in a straight line hook to hook manner and keep frame free to swivel - see Fig. 8.

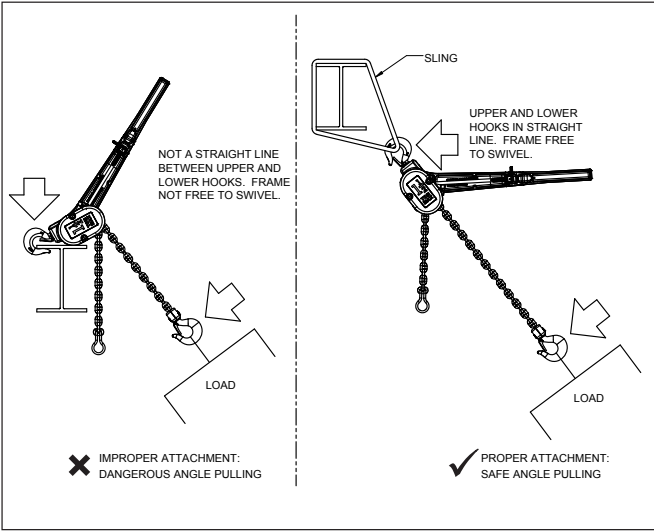

Figure 8 - Angle Pulling

Attaching Load - As discussed in installation section, attach load so that upper and lower hooks are in a straight line with the frame free to swivel on upper hook. If proposed use prevents straight line attachment, use an Anchor Sling (see page 5) or chain sling to obtain a straight line pull. Refer to Fig. 8.

To Pull or Lift Load - Put lever trigger in "UP" position. Lever pull in "UP" position shortens distance between hooks. Observe that ratchet plunger is not changed when changing from "UP" to "DOWN" or "DOWN" to "UP" positions.

To Loosen or Lower Load - Put lever trigger in "DOWN" position. Lever pull in "DOWN" position increases distance between hooks.

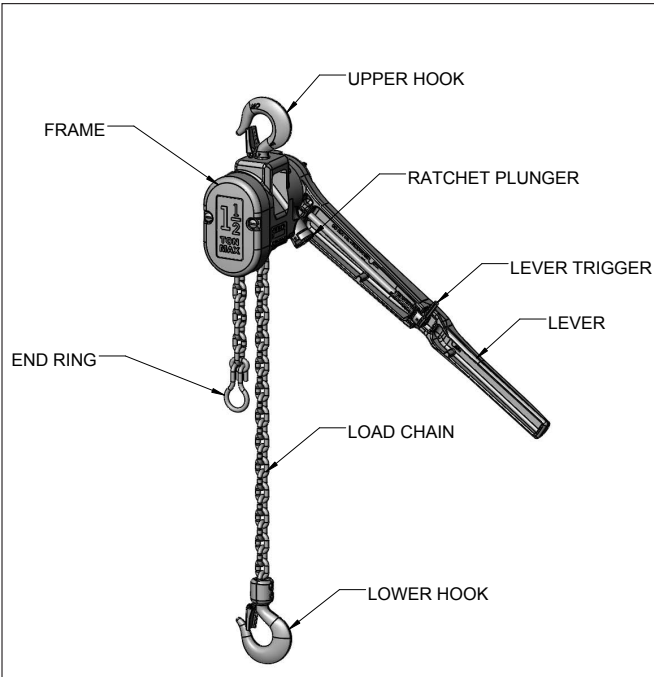

Figure 9 - CM Puller Nomenclature

⚠ WARNING

MALFUNCTION OF UNIT, RIGGING SLIP OR LOSS OF FOOTING MAY CAUSE USER TO SLIP RESULTING IN INJURY.

TO AVOID INJURY:

ALWAYS HAVE A FIRM AND SECURE FOOTING WHEN USING THE CM PULLER.

 WARNING
TO AVOID INJURY:
<ol style="list-style-type: none"> 1. Use as directed above. Failure to do so may cause injury to you or others. 2. Do not exceed capacity shown on frame or lower hook block. 3. Do not use to lift people or loads over people. 4. Do not use unless the Puller's frame and chain form a straight line between hooks. 5. Do not use if the frame is in contact with any object. 6. Do not use if the unit is damaged or malfunctions. 7. Do not use extension on lever. Use hand power only. 8. Do not use if chain is twisted, kinked or damaged.

NOTE: Refer to page 22 for information pertaining to the operation of Pullers equipped with the Load Limiter®

Inspect Puller before each use and at specified intervals as directed in inspection section.

1. When preparing to lift or move a load, ensure the load/ attachment point is firmly seated in the saddles of both hooks. Avoid off-center loading of any kind especially loading on the point of the hook. Do not load the hook latch as it is to retain slack chain as an aid in hook-up only.

 WARNING
<p>Allowing the load to bear against the hook latch and/or hook tip can result in loss of load.</p>
TO AVOID INJURY:
<p>Do not allow the load to bear against the hook latch and/or hook tip. Apply load to hook bowl or saddle only.</p>

2. When lifting or pulling, raise or move the load only enough to clear the floor or support. Check to be sure brake will hold load and that attachments to hooks and load are firmly seated. Continue the lift only after you are assured the load is free of all obstructions.
3. Do not load beyond the rated capacity. Overload can cause immediate failure of load carrying parts or create a defect causing future failure at less than rated capacity. When in doubt, use the next larger capacity of CM® Puller.
4. Operate by hand only and do not use an extension on lever. A need for an extension is an indication of either an overload or an incorrectly maintained unit. Use a Puller of adequate capacity which is in good operating condition.
5. Under no condition should any attempt be made to pry the ratchet plunger out of engagement when a load is on the unit, as this allows the load to fall.

 WARNING
<p>Pulling out or turning the ratchet plunger with a load attached will allow the load to release and may cause injury.</p>
TO AVOID INJURY:
<p>Do not pry the ratchet plunger out of engagement when a load is on the puller.</p>

6. Do not use this or any other overhead materials handling equipment for lifting persons.
7. Stand clear of all loads and avoid moving a load over the heads of other personnel. Warn personnel of your intention to move a load in their area.
8. Do not leave the load applied in an unattended manner.

9. Do not lower load chain to the point where the end ring becomes jammed against frame. (See Trouble Shooting chart on page 21).
10. The CM® Puller has been designed for hand powered operation only.
11. Do not wrap the load chain around the load and hook onto itself as a choker chain.
12. Do not wrap load chain around the load or bring the load in contact with the Puller. Doing this will result in the loss of the swivel effect of the hook which could mean twisted chain and a jammed liftwheel. The chain could be damaged at the hook.
13. Do not operate the hoist unless it is rigged to pull in a straight line from hook to hook, and the frame is free to swivel on the upper hook. Refer to Fig. 8.
14. Never operate the hoist when flammable materials or vapors are present. Contact between metal parts may produce sparks that can cause a fire or explosion.
15. **STAY ALERT!** Watch what you are doing and use common sense. Do not use the hoist when you are tired, distracted or under the influence of drugs, alcohol or medication causing diminished control.

INSPECTION

To maintain continuous and satisfactory operation, a regular periodic inspection procedure must be initiated so that worn, damaged and missing parts can be replaced before the unit becomes unsafe. The frequency of inspection must be determined by the individual application.

The following list gives an inspection procedure for normal usage under normal conditions.

When the unit is subjected to heavy usage or dusty, gritty, moist or corrosive atmospheric conditions, shorter time periods must be assigned. Inspection must be made of all parts for unusual wear, corrosion or damage, in addition to those specifically mentioned in the schedule below. Make certain that the unit is complete and contains all parts including hook latches and end ring.

Any parts that are deemed unserviceable must be replaced with new parts before the unit is returned to service. It is very important that the unserviceable parts be destroyed and properly disposed of to prevent their possible future use as a repair item. Use only Columbus McKinnon supplied repair parts as other parts may look the same but may not be to proper specifications.

Inspection of hoists is divided into two general classifications designated as "frequent" and "periodic".

INSPECTION AND MAINTENANCE CHECK LIST
HAND OPERATED LEVER HOIST

ENGLISH

Type of Hoist _____ Capacity (Tons) _____
 Location _____ Original Installation Date _____
 Manufacturer _____ Manufacturer's Serial No. _____

Item	Frequency of Inspection		Possible Deficiencies	OK	Action Required
	Frequent	Periodic			
	Daily	Every 3 Months to Annually as defined per ASME B30.21			
Brake Mechanism	*	*	Slippage or excessive drift. Worn, glazed or contaminated friction discs. Thickness of friction disc less than 0.100 in (2.5 mm).		
Lever, Lever plunger, ratchet plunger	*	*	Binding, bends, cracks, other damage		
Directional Lever Trigger	*	*	Binding and does not move freely.		
Load Chain	*	*	Inadequate lubrication, excessive wear or stretch, cracked damaged or twisted links, corroded or clogged with foreign material, or improper reeving.		
Hooks	*	*	Excessive throat opening, twisted, damaged or non-operating hook latch, chemical damage. Cracks (Use dye penetrant, magnetic or other suitable detection method at least once a year).		
Lower Hook Block, Upper Hook Block, Upper Hook Pin, Chain Guide, Bushings, Gears, Pinion and Friction Hub		*	Cracks, distortion, excessive wear, corrosion or build-up of foreign material.		
Tip of Pawls and Lever Pawl Teeth of Ratchet and Lever Ratchet		*	Cracks, distortion, excessive wear, corrosion or build-up of foreign material.		
Pockets of Liftwheel, Stripper and Side Plates		*	Cracks, distortion, excessive wear, corrosion or build-up of foreign material.		
Nuts, Bolts, Pins and Rivets		*	Cracks, bending, loose, stripped threads.		
Pawl Springs, Directional Pawl Spring, and Spring		*	Corrosion, stretched or broken.		
Chain Stop		*	Missing, cracked, not secured to chain, not properly positioned.		
Nameplate, Warning Labels and Free Chaining		*	Missing, Damaged or illegible.		

NOTE: Refer to Maintenance and Inspection Sections of this manual for further details.

FREQUENCY OF INSPECTION

Frequent - Indicates items requiring inspection daily or before each use. These inspections may be performed by the operator if properly designated.

Periodic - Indicates items requiring inspection every three months. Inspections to be performed by or under the direction of a properly designated person. The exact period of inspection will depend on frequency and type of usage. Determination of this period will be based on the user's experience. It is recommended that the user begin with a quarterly inspection and extend the periods to semi-annually or annually based on the user's quarterly experience.

NOTE: This inspection and maintenance check list is in accordance with our interpretation of the requirements of the Safety Standard for Lever Hoists ASME B30.21. It is, however, the ultimate responsibility of the employer/user to interpret and adhere to the applicable requirements of this safety standard.

NOTE: To perform some of the periodic inspections, it is necessary to partially disassemble the hoist. Refer to Disassembly-Assembly starting on page 10. Also, the external conditions may show the need for more detailed inspection which, in turn, may require the use of non-destructive type testing.

HOOK INSPECTION

Hooks damaged from chemicals, deformations or cracks, or that have more than a 10 degree twist from the plane of the unbent hook or excessive opening or seat wear must be replaced.

Also, on latch type hooks, hooks that are opened and allow the latch to disengage the tip, must be replaced.

Any hook that is twisted or has excessive throat opening indicates abuse or overloading of the unit. Other load sustaining components of the hoist should be inspected for damage.

Check to assure latch is not damaged or bent and that it operates properly with sufficient spring pressure to keep the latch tightly against the tip of the hook and allow the latch to spring back to the tip when released. If the latch does not operate properly, it should be replaced.

The charts below (Table 2, Fig. 10 and 11) should be used to determine when the hook must be replaced.

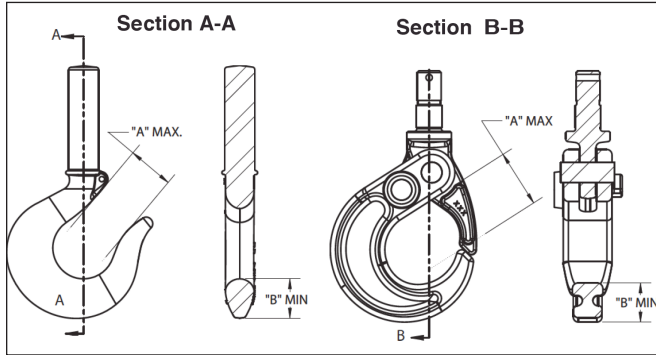

Figure 10. Hook Throat Opening

CHAIN INSPECTION

WARNING

Using other than cm supplied load chain may cause the chain to jam in the hoist and/or allow the chain to break and the load to drop.

TO AVOID INJURY:

Due to size requirements and physical properties, use only CM® hoistaloy® load chain in the CM puller.

First clean chain with a non-caustic/non-acid type solvent and make a link by link inspection for nicks, gouges, twisted links, weld spatter, corrosion pits, striations (minutes parallel lines), cracks in weld areas, wear and stretching. Chain with any one of these defects must be replaced.

Slack the portion of the chain that normally passes over the liftwheel. Examine the interlink area for the point of maximum wear

(polishing). Measure and record the stock diameter at this point of the link. Then measure stock diameter in the same area on a link that does not pass over the liftwheel (use the link adjacent to the end ring for this purpose). Compare these two measurements. If the stock diameter of the worn link is 0.010 inches (0.254 mm), or more, less than the stock diameter of the unworn link, the chain must be replaced.

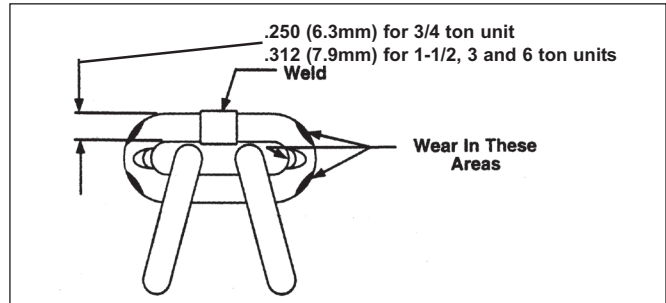

Figure 11. Chain Inspection

Also check chain for stretch using a vernier caliper as shown above. Select an unused, unstretched section of chain (usually at the loose end) and measure and record the length over 11 chain links (pitches). Measure and record the same length on a worn section of chain. Obtain the amount of stretch and wear by subtracting the measurement of the unworn section from the measurement of the worn section. If the result (amount of stretch and wear) is greater than 0.145 inch (3.7 mm), the chain must be replaced.

Use only a "Knife-Edge" caliper to eliminate possibility of false reading by not measuring full pitch length. Note that worn chain can be an indication of worn hoist components. For this reason, the hoist's frame, stripper, and liftwheel should be examined for wear and replaced as necessary when replacing worn chain.

Also, the load chain is specially heat treated and hardened and should never be repaired.

IMPORTANT: Do not use replaced chain for other purposes such as lifting or pulling. Load chain may break suddenly without visual deformation. For this reason, cut replaced chain into short lengths to prevent use after disposal.

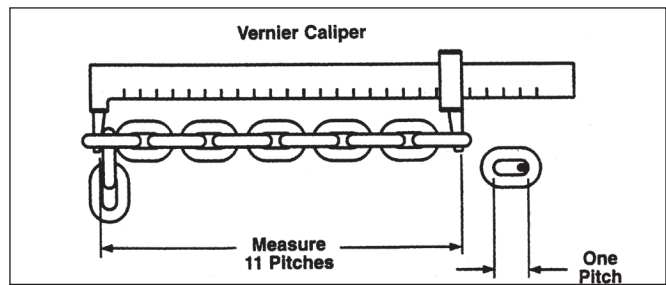

Figure 12. Gaging Load Chain Wear

Table 2 – Hook Throat Opening

Models	Latch Type Upper Hook		Latch Type Lower Hook		Latchlok® Upper Hook		Latchlok® Lower Hook	
	"A" Max	"B" Min	"A" Max	"B" Min	"A" Max	"B" Min	"A" Max	"B" Min
3/4 Ton	1.18" (30.0mm)	.86" (21.8mm)	1.18" (30.0mm)	.85" (21.6mm)	1.45" (36.8mm)	.70" (17.8mm)	1.45" (36.8mm)	.70" (17.8mm)
1-1/2 Ton	1.30" (32.9mm)	1.00" (25.4mm)	1.31" (33.3mm)	1.03" (26.1mm)	2.55" (64.8mm)	1.26" (32.0mm)	2.55" (64.8mm)	1.26" (32.0mm)
3 Ton	1.43" (36.3mm)	1.20" (30.3mm)	1.43" (36.3mm)	1.20" (30.3mm)	2.55" (64.8mm)	1.26" (32.0mm)	2.55" (64.8mm)	1.26" (32.0mm)
6 Ton	1.97" (50.0mm)	1.63" (41.4mm)	1.97" (50.0mm)	1.63" (41.4mm)	2.55" (64.8mm)	1.26" (32.0mm)	2.55" (64.8mm)	1.26" (32.0mm)

CHAIN LUBRICATION

⚠ WARNING
Used motor oils contain known carcinogenic materials.
TO AVOID HEALTH PROBLEMS:
Never use used motor oils as a chain lubricant. Only use Lubriplate® bar and chain oil 10-R as a lubricant for the load chain.

A small amount of lubricant will greatly increase the life of the load chain. Do not allow the chain to run dry. Keep it clean and lubricate at regular intervals with Lubriplate® Bar and Chain Oil 10-R (Fiske Bros. Refining Co.) or equal lubricant. Normally, weekly cleaning and lubrication is satisfactory, but under hot and dirty conditions, it may be necessary to clean the chain at least once a day and lubricate it several times between cleanings.

When lubricating the chain, apply sufficient lubricant to obtain natural run-off and full coverage, especially in the interlink area.

MAINTENANCE

LUBRICATION

Except for the load chain (see “Chain Lubrication” above), the hoist requires no additional lubrication.

⚠ WARNING
The lubricants used in and recommended for the puller may contain hazardous materials that mandate specific handling and disposal procedures
TO AVOID INJURY:
Contact and contamination handle and dispose of lubricants only as directed in applicable material safety data sheets and in accordance with applicable local, state and federal regulations.

⚠ WARNING
Using any grease or lubricant on the braking surfaces will cause brake slippage and loss of load control which may result in injury and/or property damage.
TO AVOID INJURY:
Do not use any grease or lubricant on braking surfaces. The brake is designed to operate dry.

However, when the unit has been disassembled for cleaning, inspection or repairs, the various part should be lubricated as indicated in “Assembly” start on page 10 using the specified lubricants. If necessary, these lubricants can be obtained from CM (refer to page 20).

Note: When lubricating parts adjacent to the brake, do not use an excessive amount of lubricant which could seep onto the brake surfaces.

EXTERIOR FINISH

The exterior surfaces of the Puller has a durable, scratch resistant baked powder coating. Normally, the exterior surfaces can be cleaned by wiping with a cloth. However, if the finish is damaged, compatible touch-up paint can be purchased from CM. Refer to page 20 for information on ordering the paint.

PREVENTIVE MAINTENANCE

In addition to the above frequent inspection procedure, a maintenance program should be established to prolong the useful life of the tool and maintain its reliability and continued safe use. The program should include the frequent inspections with particular attention being paid to the lubrication of various components using the recommended lubricants. Be sure to completely disassemble the unit every three months and check for excessive wear of the parts as indicated in the following table. Worn parts should be replaced before the Puller is returned to service.

DISASSEMBLY

(Refer to pages 11-19 for illustrations and key numbers of parts listed below. Also, see special disassembly instructions on page 22 for units equipped with Load Limiter).

Two points of caution to be observed in disassembly are:

1. When removing the Ratchet Plunger Spring Pin. This pin retains a spring which is in compression and can spring out.
2. The dead end pin on the 3 and 6 ton units has a tapered spline. Remove this pin by tapping on the end opposite the splined grooves.

ASSEMBLY

(Refer to pages 11-19 for illustrations and key numbers of parts listed below. Also, see special assembly instructions on page 22 for units equipped with Load Limiter).

IMPORTANT: Following assembly test the unit as discussed in the Testing section (page 20).

The following points should be observed when assembling the Puller. Also, refer to the above Warning concerning the brake.

1. Ratchet Plunger
 - a. Coat tip and sides of small diameter with a light film of a lubricant consisting of 1 lb.(4.6kg) of graphite #590 (Superior Graphite Co.) and 2 lbs. (.92kg.) of Lubriko M-32 (Master Lubricant Co.).
 - b. The Ratchet Plunger Spring must be held depressed when driving in the Ratchet Plunger Pin thru the lugs on the frame.
2. Frame Bushing
 - a. All Frame Bushings should be given a light coating of lubricant as specified above.
3. Brake Assembly
 - a. Assemble one Friction Washer.
 - b. Check Bushing in Ratchet to be sure it is flush or below the surface of the Ratchet on both sides. Assemble Ratchet with Ratchet Teeth facing as showing in Fig. 13.

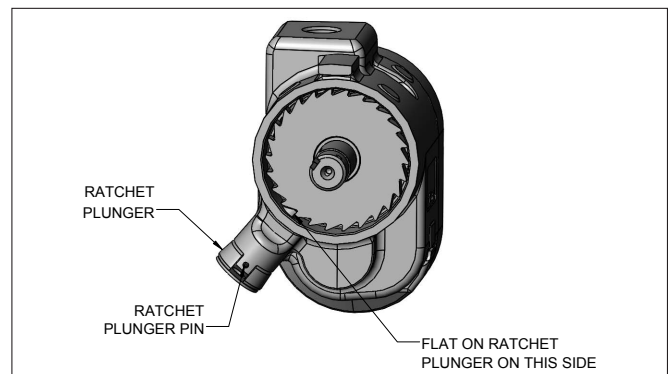

Figure 13. - Ratchet and Ratchet Plunger Assembly

- c. Place second Friction Washer on the Ratchet.
- d. Apply a light film of Anderol #786 (Nuodex, Inc.) to the inside diameter of the Lever Ratchet Hub on the second friction washer as shown in Fig. 14.
- e. Lubricate Brake Cam by coating cam faces and outside surface with a light film of Anderol #786 (Nuodex, Inc.) grease.
- f. Assemble Brake Cam onto shaft then insert Brake Cam Key rounded end first - the key must be positioned as shown in Fig. 14.

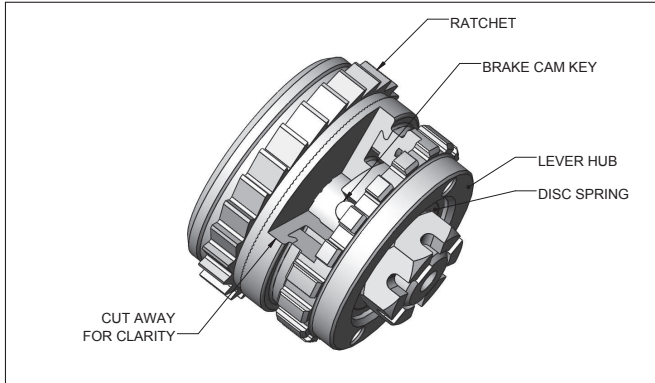

Figure 14. - Brake Parts

- g. Turn Lever Ratchet Hub clockwise until vertical ends (shoulders) of the helical surfaces of lever ratchet hub and brake cam are in contact. Place the disc spring on the brake cam with the large end against the brake cam. Assemble brake adjusting nut to shaft and tighten nut until snug. Then continue to tighten nut at least one but no more than two slots in order to align hole in shaft with slot in nut. Insert the cotter pin and bend the ends of same as shown in Fig. 15.

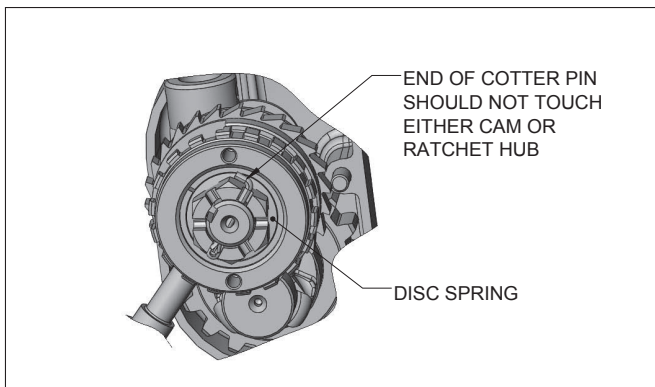

Figure 15. - Brake Nut Cotter Pin Assembly

- 4. Gears (1-1/2, 3 & 6 Ton Units)
 - a. Lubricate the gears with 3-1/2 to 4 oz. (118 ml) of Texaco Novatex #2 Grease or equal, by spreading some on Gear Teeth and balance in the lower portion of Gear Cover.
- 5. Chain Guide (1-1/2, 3 & 6 Ton Units)
 - a. When installing the Chain Guide, the Chain Guide Screw must be tightened to a torque of 10 to 13 inch pounds.
- 6. Lever Assembly
 - a. When assembling Lever Trigger be sure to maintain relation of Lever Plunger tip and Lever Trigger as shown in Fig. 16.
 - b. Coat inside of Lever Head with Lubriko M-32. Wipe off excess lubricant.

IMPORTANT: To assure extra-long life and top performance, be sure to lubricate the various parts of the CM Puller using the lubricants specified above. If necessary, these lubricants may be purchased from CM®. Refer to page 20 for information on ordering the lubricants.

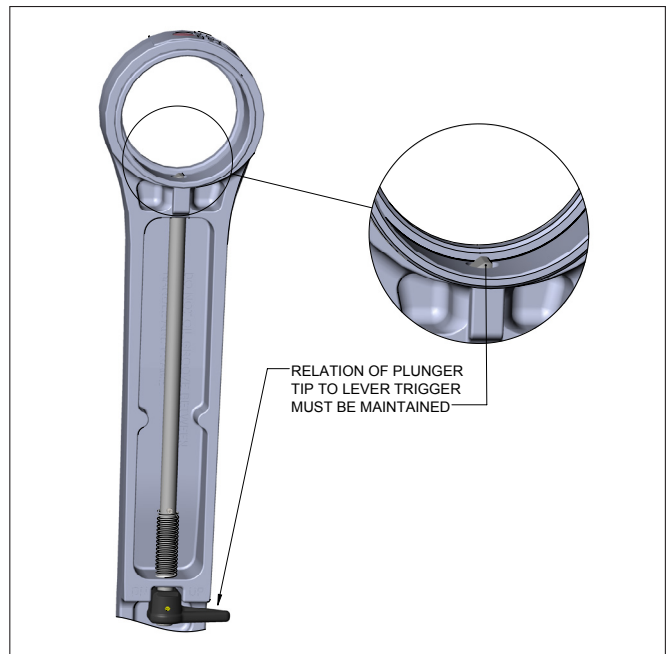

Figure 16. - Lever Assembly

REEVING

NOTE: Units should be in the free wheeling mode before reeving. See page 6.

- 1. **3/4 Ton Unit Uses CM® 1/4 in. (6.3mm) Stock Disc Grade Load Chain.**
 Start upstanding link (see Fig. 17) of hook end of load chain into Plunger Boss side (at side opposite that is marked on the chain guide "Lower Hook Side") of clover leaf chain guide and onto liftwheel with weld side of upstanding links facing away from liftwheel (see Fig. 17). Continue to feed chain into opening while turning Lever Cap clockwise until end of chain can be reached and pulled through. Do not force chain over liftwheel - if turning of Lever Cap becomes difficult, back off and start over - otherwise, the chain could become jammed between liftwheel and frame.

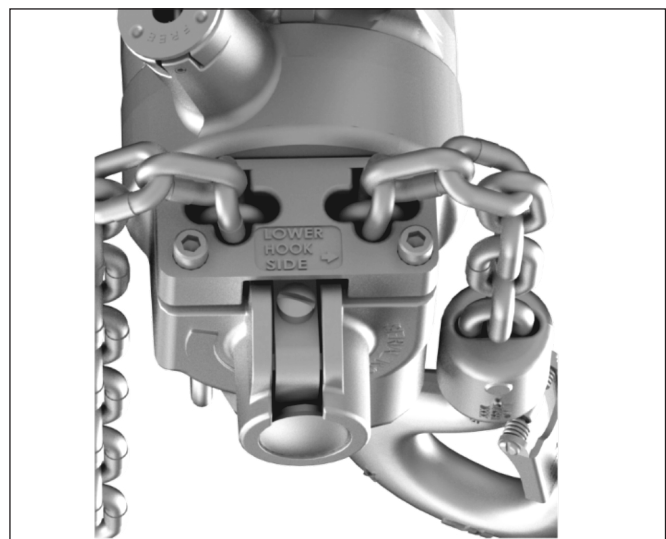

Figure 17. - Chain Assembly - Hook End, 3/4 Ton

2. **1-1/2 Ton Unit Uses CM® 5/16 in. (7.9mm) Stock Disc Grade Load Chain.**

Start upstanding link (see Fig. 17) of hook end of load chain onto liftwheel (at side opposite that marked on casting "Lower Hook Side") with weld side of upstanding links facing away from liftwheel (at side opposite that marked on casting "Lower Hook Side") with weld side of upstanding links facing away from liftwheel. Continue to feed chain onto liftwheel while turning Lever Cap clockwise until end of chain can be reached and pulled through. Do not force chain over liftwheel - if turning of Lever Cap becomes difficult, back off and start over - otherwise, the chain could become jammed between liftwheel and frame.

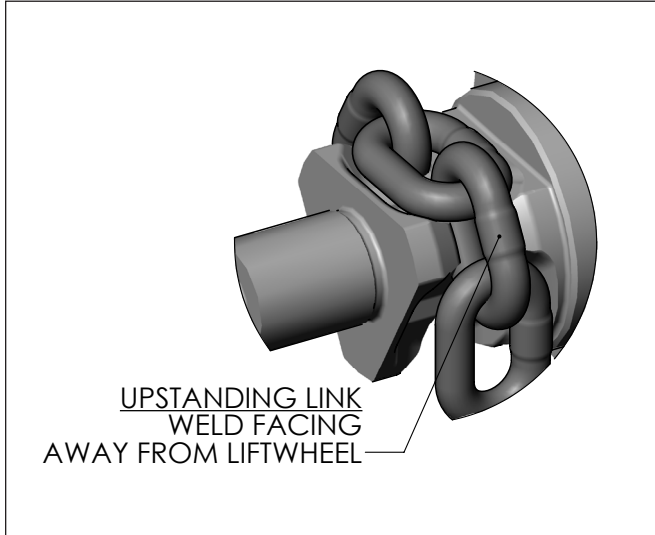

Figure 18. - Chain Assembly - Hook End, 1 1/2 Ton

3. 3 Ton Uses CM® 5/16 in. (7.9mm) Stock Disc Grade Load Chain.

- a. Start upstanding link (see Fig. 18) of dead end (end opposite end ring) onto liftwheel (at side opposite that marked on casting "Lower Hook Side") with weld side of upstanding links facing away from liftwheel. Continue to feed chain onto liftwheel while turning Lever Cap clockwise until end of chain can be reached. Pull through about three feet of chain. Do not force chain over liftwheel - if turning of Lever Cap becomes difficult, back off and start over - otherwise, the chain could become jammed between liftwheel and frame.
- b. Place the Puller in vertical position.
- c. After checking to be sure there is no twist in chain, feed end of chain through Hook Block and around Lower Sheave.
- d. Secure end of chain to Hoist Hanger with Dead End Pin.

4. 6 Ton Unit Uses CM® 5/16 in. (7.9mm) Stock Disc Grade Load Chain.

- a. Start first link of dead end (end opposite End Ring) onto Liftwheel in flat position (at side opposite that marked on casting "Lower Hook Side") with weld side of upstanding links facing away from Liftwheel. Continue to feed chain onto Liftwheel while turning Lever Cap clockwise until end of chain can be reached. Pull through about six feet of chain. Do not force Chain over Liftwheel if turning of Lever Cap becomes difficult, back off and start over - otherwise, the chain could become jammed between Liftwheel and Frame.
- b. Place the Puller in vertical position.
- c. After studying Fig. 20 and checking to be sure there is no twist in chain, feed end of chain down through Hook Block and around one lower Sheave, up over upper Sheave, down through Hook Block and around second lower Sheave.
- d. Secure end of chain to the Hanger with Dead End Pin.



Figure 19. - Reeving 3-Ton

5. All Units

- a. Lubricate chain with Lubriplate®, Bar and Chain Oil 10-R (Fiske Bros. Refining Co.) or equal Lubricant.
- b. Important: Load Chain End Ring should be assembled and left on end of the load chain to prevent chain from being run out of unit.



Figure 20. - Reeving 6-Ton

6. 3/4 and 1-1/2 Ton Units

- a. Coat undersides of hook Knob and Seat of Hook Blocks with a light film of Lubriko M-32 (Master Lubricants Co.) or equal grease.
- b. After tightening Hook Block Screw, lock in place by prick punching two spots 180 apart on edge of counterbore to drive metal in to serrations of head of screw. If screw has been removed and replaced, always use new spots for locking.

7. Test the unit as discussed in the Testing section (page 20).

REPAIR PARTS

ORDERING INFORMATION



ENGLISH

⚠ WARNING
Using “commercial” or other manufacturer’s parts to repair the CM® pullers may cause load loss.
TO AVOID INJURY:
Use only CM® supplied replacement parts. Parts may look alike but CM® parts are made of specific materials or processed to achieve specific properties.

The following information must accompany all correspondence or repair parts orders.

1. Puller capacity
2. Serial Number - this is stamped on the Puller frame.

For parts orders also specify

1. Quantity desired
2. Key number of part
3. Part Name
4. Part number of the part

When ordering replacement parts, consideration should be given to the need to replace other items, (bushings, fasteners, etc.) and items that may be damaged or lost during disassembly or just unfit for future use because of deterioration from age or service.

Parts should be ordered from CM’s® Master Parts Depots conveniently located throughout the United States and Canada. Refer to the inside of the front cover of this manual to locate the Master Parts Depot nearest you.

RECOMMENDED SPARE PARTS

To ensure continued operation of the Puller, it is recommended that two friction washers for each Puller in service be kept on hand at all times to replace friction washers that are worn to a thickness of less than .100 inch, contaminated or glazed. Refer to page 13 for ordering instructions.

Part Name	No. Req'd	Part Numbers			
		Capacity - tonnes			
		¾	1 ½	3	6
Friction Washer	2	40904			
Upper Hook Assembly (Includes Latch)	1	40601	40603	40605	40607
Lower Hook Assembly (Includes Latch)	1	40602	40604	40606	40608
Load Chain	1	85839	85847		
Latch Kit	2	45661	45662	45663	45665

CM PULLER PARTS LIST

ENGLISH

Item No.	No. Req'd	Part Name	Part Numbers			
			Capacity - tonnes			
			¼	1 ½	3	6
1	1	Frame with Bushings (3/4 Tons)	40684C	-		
2	1	Frame with Bushings (1 ½-6 Tons)	-	40695C		
3	1	Frame Expansion Plug	940787	-		
4	1	Stripper Screw	982688	-		
5	2	Chain Guide Attaching Screw	987274	-		
6	1	Stripper	40728	-		
7	2	Gear Cover Screw	-	982689		
8	1	Chain Guide Attaching Screw	-	940860		
9	1	Friction Hub Key	-	40917		
10	1	Pinion Thrust Washer	-	40789		
11	1	Brake Cam Key	40824			
12	1	Brake Adjusting Nut	40785			
13	1	Brake Adjusting Nut Cotter Pin	940805			
14	2	Lever Cap Screw	982717			
15	1	Liftwheel	40130	40140		
16	1	Chain Guide	40698B	24718		
17	1	Liftwheel Bushing (Gear End)	-	40822		
18	1	Liftwheel Bushing (Brake End)	-	40817		
19	1	Pinion Shaft Bushing (Brake End)	-	40821		
20	1	Pinion Shaft Bushing (Pinion End)	-	40819		
21	1	Gear Cover	-	40927C		
22	1	Pinion Shaft	-	40480		
23	1	Friction Hub	-	40446		
24	2	Friction Washer	40904			
25	1	Ratchet with Bushing	40662			
26	1	Lever Ratchet Hub for units not equipped with Load Limiter	40570			
27	1	Brake Cam	40122			
28	1	Lever Assembly (Includes Lever, Expansion Plug, Plunger, Plunger Spring, Spring Pin Trigger, Trigger Pin, Warning Label and Nameplate)	40663 For units without Load Limiter 40928 For units with Load Limiter			
29	1	Load Sentry Assembly	4096	4098		
30	1	Ratchet Plunger	40517			
31	1	Ratchet Plunger Spring	40742			
32	1	Ratchet Plunger Spring Pin	983880			
33*	1	Upper Hook Assembly (Includes Latch)	40601	40603	40605	40607
34	1	Upper Hook Nut or Collar	986383	45384	40382	70393
35	1	Upper Hook Pin	983768	45941	982335	983787
36	1	Upper Hook Washer	-			40736
37	1	Anchor Sling	4071	4072	-	
38	1	Lever Cap	40900			
39	1	Disc Spring	82297			
40	1	End Ring	40471			
41	1	Hoist Hanger	-	40151		40171
42	1	Adapter Sleeve	-	40790		-
43	1	Hanger Screw (3 Ton)	-	982587		-
44	1	Hanger Screw Washer (3 Ton)	-	940807		-

CM PULLER PARTS LIST CONT.

ENGLISH

Item No.	No. Req'd	Part Name	Part Numbers			
			Capacity - tonnes			
			¾	1 ½	3	6
45	1	Dead End Pin (3 Ton)	-		40851	-
46	1	Hoist Hanger Set Screw (3 Ton)	-		986304	-
47	1	Hanger Screw (6 Ton)		-		40500
48	1	Dead End Pin (6 Ton)		-		40853
49	1	Bearing Retainer Snap Ring		-		10008305
50	1	Hanger Screw Washer (6 Ton)		-		45930
51	1	Hanger Screw Nut (6 Ton)		-		40383
52	1	Hanger Screw Nut Pin (6 Ton)		-		983791
53	1	Upper Sheave		-		40172
54	2	Upper Sheave Bearing		-		88429
55*	1	Lower Hook Assembly (Includes Latch)	40602	40604		-
56	1	Hook Block Drilled	40120	40142		-
57	1	Hook Block Tapped	40121	40143		-
58	1	Hook Block Screw	40854	40855		-
59*	1	Lower Hook Assembly (Includes Latch)		-	40606	40608
60	1	Lower Hook Washer	-	-	50454	40736
61	1	Lower Hook Nut		-	40382	70393
62	1	Lower Hook Nut Pin		-	982335	983787
63	3	Lower Hook Block Screw		-	940812	-
64	3	Lower Hook Block Screw Lock Washer		-	940830	-
65	3	Lower Hook Block Screw Nut		-	945820	-
66	1	Reeving Caution Plate		-	40930	-
67	1	Lower Sheave Bearing Spacer		-		40796
68	2	Bearing Retainer Snap Ring		-		10008305
69	2	Expansion Plug		-		940737
70	1	Lower Sheave (3 Ton)		-	40166	-
71	2	Lower Sheave (6 Ton)		-		40172
72	4	Sheave Bearing (6 Ton)		-		88429
73	2	Lower Hook Block (3 Ton)		-	40689	-
74	1	Lower Hook Block (6 Ton)		-		40176
75	1	Load Chain	85839		85847	
76	2	Latch Kit	45661	45662	45663	45665
77	1	Lever Plunger			40462	
78	1	Lever Expansion Plug			940801	
79	1	Lever Plunger Spring			40735	
80	1	Lever Plunger Pin			983766	
81	1	Lever Trigger			40113	
82	1	Lever Trigger Pin			983768	
83	1	Warning Label	40975	40978	40979	40980
84	1 ea	Operating Tag and Tie			Tag 40976 and Tie 982912	
85	1	Load Limiter Kit (Includes Lever)	4190		4191	
86	1	Lever Ratchet Hub for units equipped with Load Limiters			40182	
87	1	Capacity or CM Label	-	40908		40907

*If Latchlok hook is required, part numbers are:

- Upper Hook: 1000 for 3/4t, 1002 for 1-1/2t, 1004 for 3t, 1027 for 6t.
- Lower Hook: 1001 for 3/4t, 1003 for 1-1/2t, 1005 for 3t, 1007 for 6t.

0.75T HOIST BODY

ENGLISH

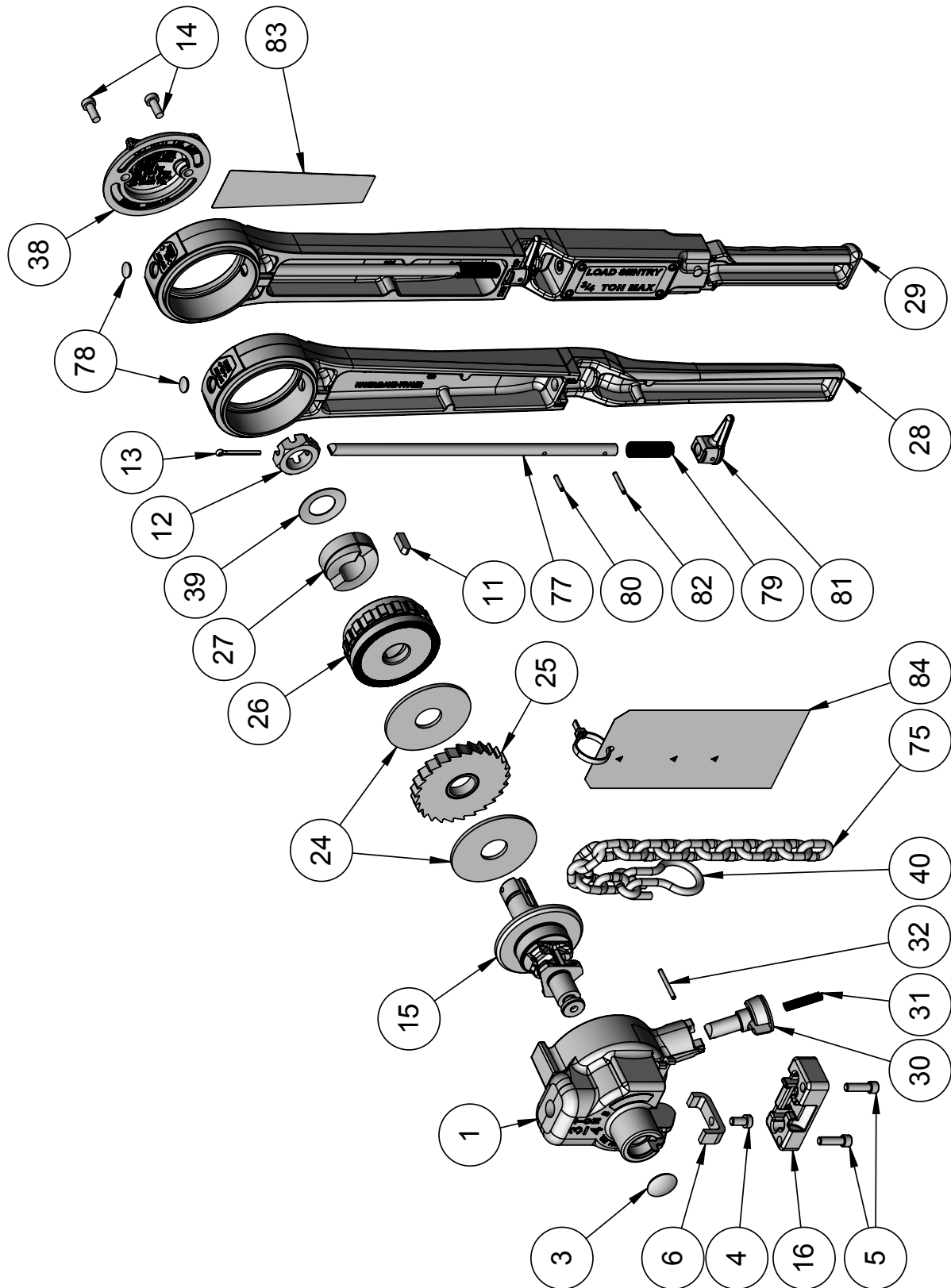

1.5-6T HOIST BODY

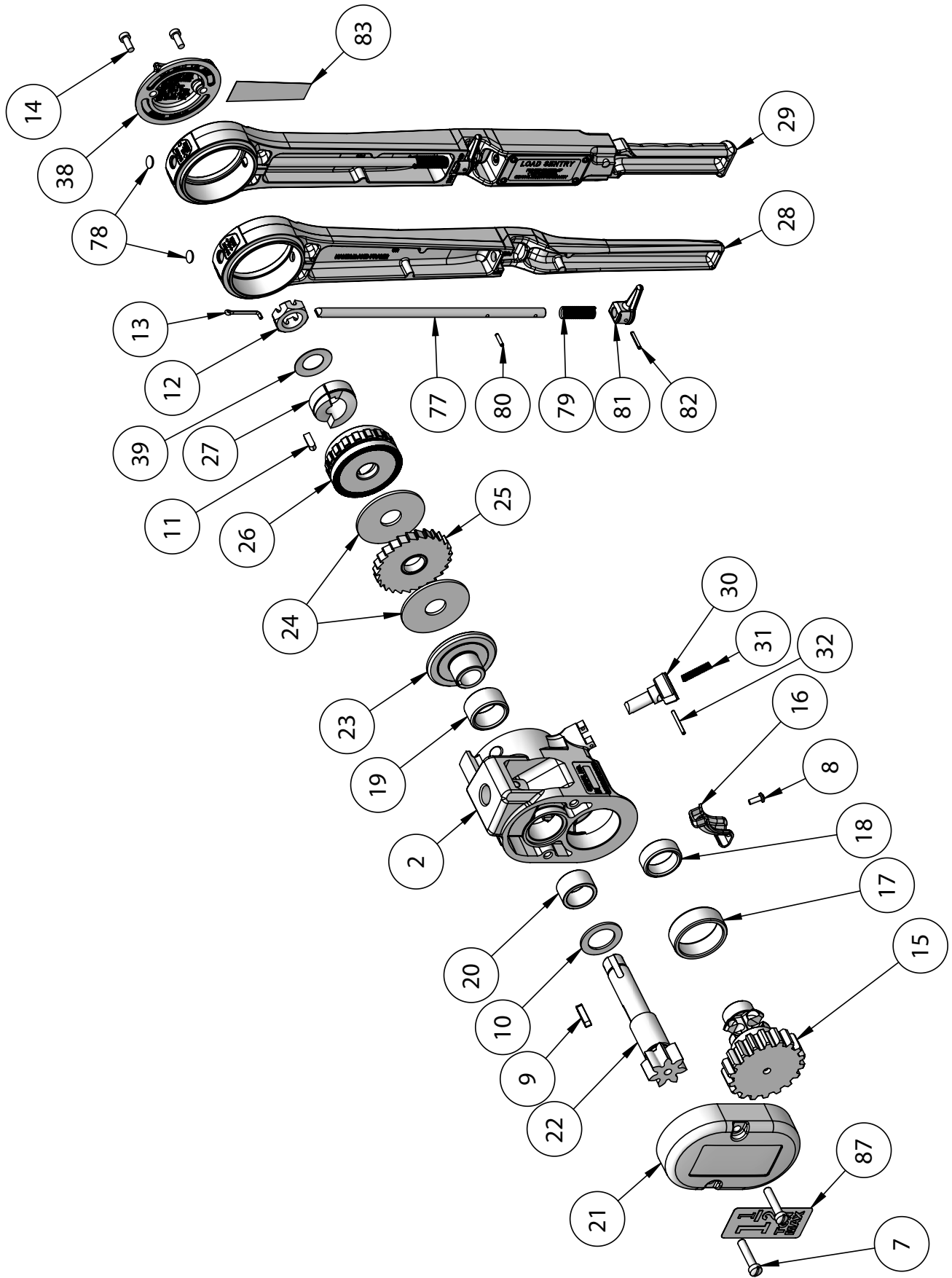

LOWER HOOKS

ENGLISH

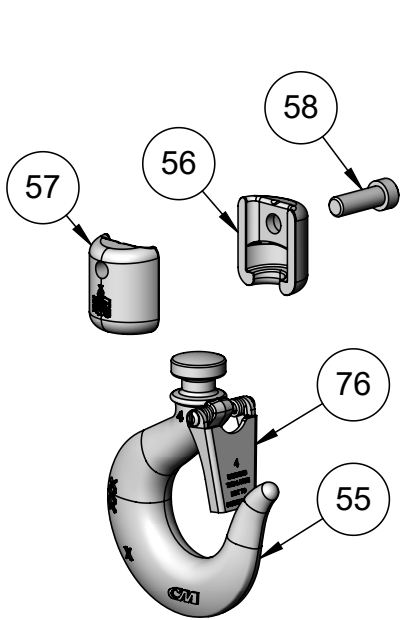

**0.75 & 1.5 TONNE
LOWER LATCH-TYPE HOOK**

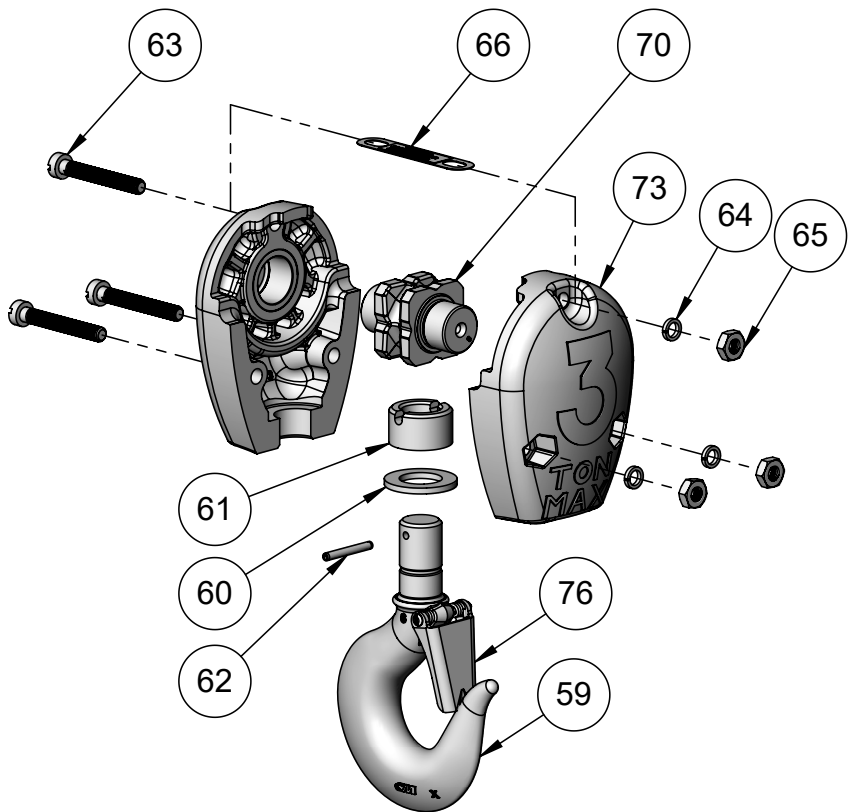

**3 TONNE
LOWER LATCH-TYPE HOOK**

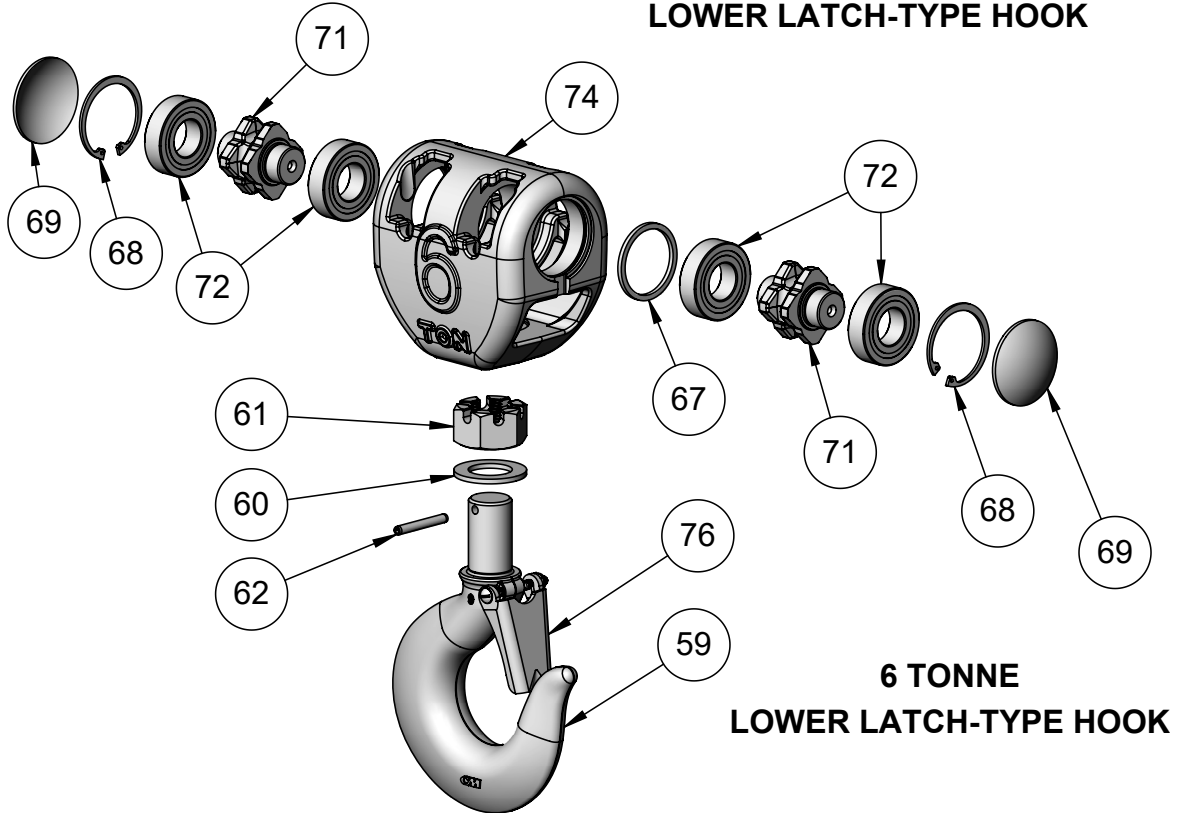

**6 TONNE
LOWER LATCH-TYPE HOOK**

SUSPENSION HOOKS

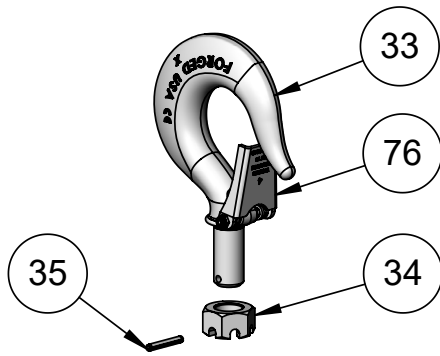

**0.75 & 1.5 TONNE
HOOK SUSPENSION**

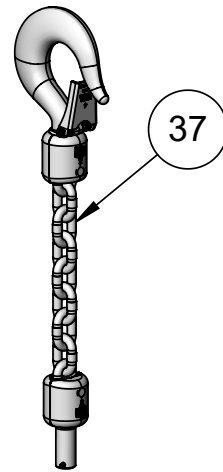

**0.75 & 1.5 TONNE
ANCHOR SLING**

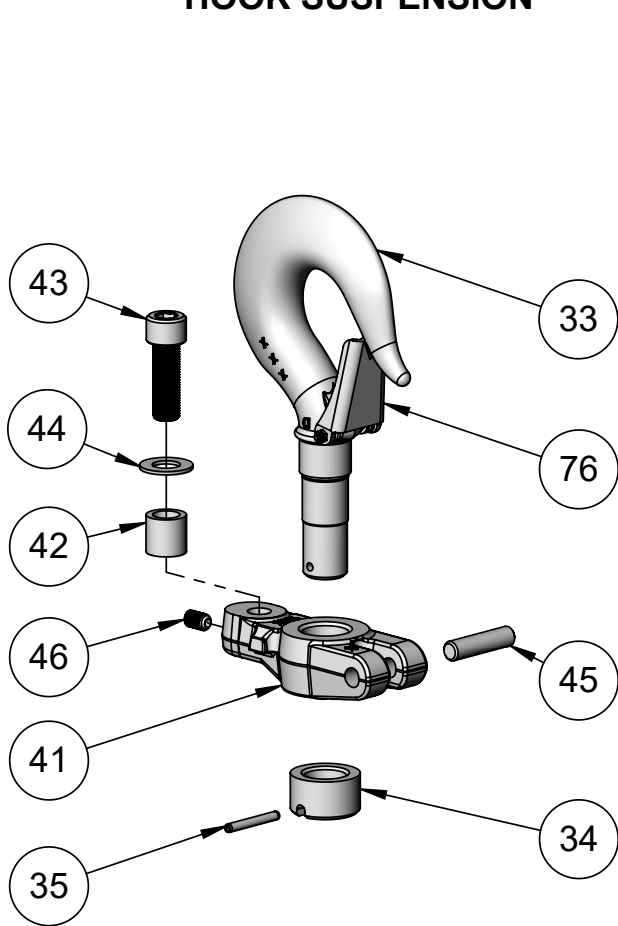

**3 TONNE
HOOK SUSPENSION**

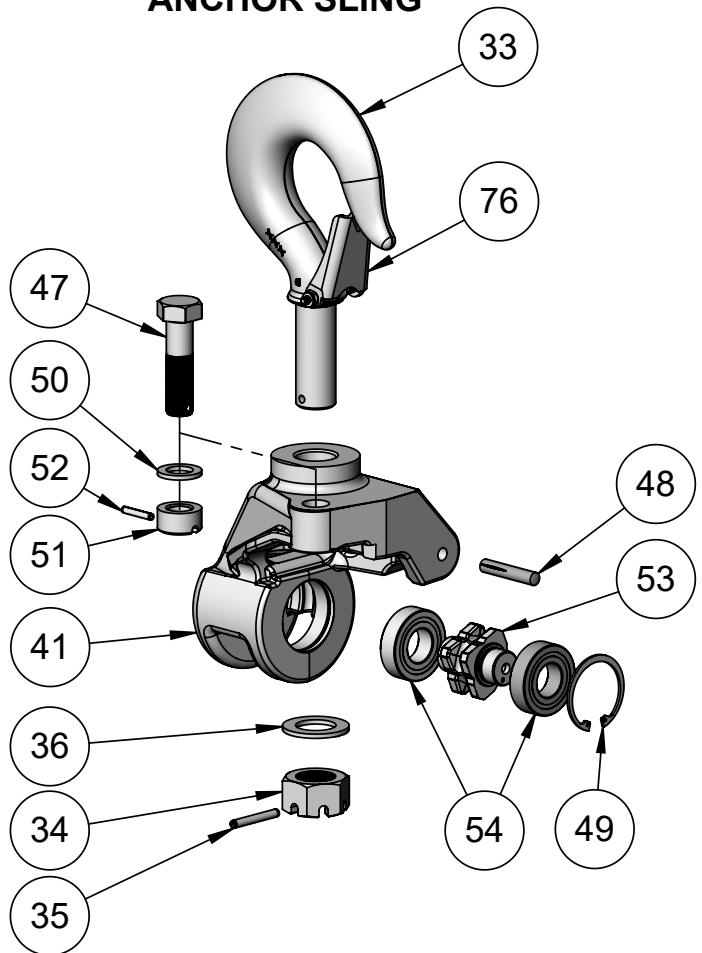

**6 TONNE
HOOK SUSPENSION**

**PART NUMBERS FOR PACKAGED LUBRICANTS USED IN THE PULLERS
(REFER TO PAGES 10-12 FOR LUBRICATION INSTRUCTIONS)**

Lubricant Usage	Type of Lubricant	Part Numbers and Packaged Quantities of Lubricants
Tip of Ratchet Plunger and Seat for Knob Hook	Grease-Graphite Mixture	40626 (1 LB., 46 kg. CAN)
Brake Cam	Dry-Lube-Oil-Graphite Mixture	40553 (½ LB., .23 kg CAN)
Frame Bearings and Inside of Lever Head	Grease	40630 (1 LB., .46 kg. CAN)
Gears (1-1/2, 3 and 6 Ton Units)	Grease	28610 (1 LB., .46 kg. CAN) 28613 (4 LB., 1.8 kg. CAN)
Between Upper Hook Nut and Washer	Grease-Graphite Mixture	40626 (1 LB., .46kg. CAN)
Load Chain	Oil	28608 (1 PT., .5L CAN) 28619 (1 GAL., 3.8L CAN)

When ordering lubricants, specify the type of lubricant, part number and packaged quantity required.

TOUCH-UP PAINT FOR THE PULLER:

* (1) case (12-12 oz., 354 ml Aerosol Cans) of Orange Touch-up Paint Part Number 84190.

*Touch-up paints are only available in case quantities.

NOTE: When painting the Pullers, also order warning labels and capacity labels that may be coated during painting.

CUTTING CHAIN

CM® Hoistaloy® load chain is hardened for wear resistance and is difficult to cut. However, the following methods are recommended when cutting off a length of worn chain.

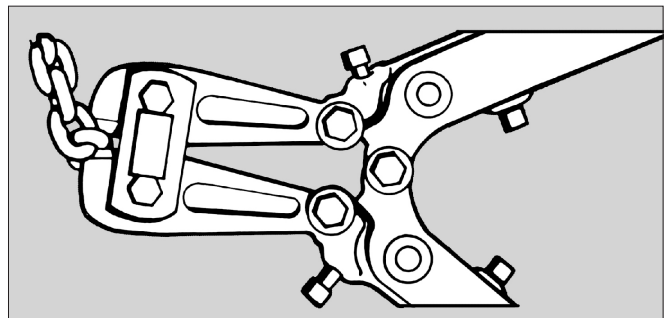

Figure 22. - Cutting Chain with a Bolt Cutter

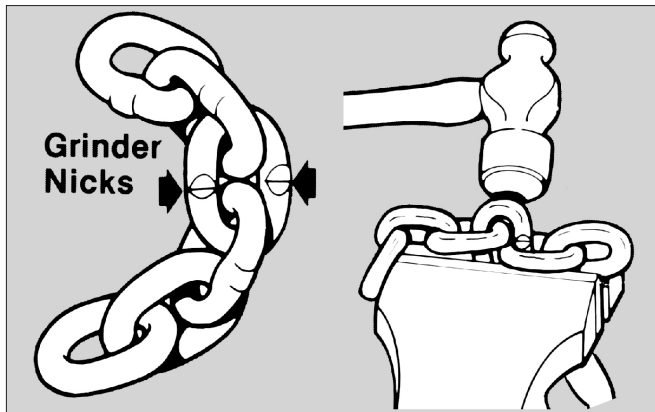

Figure 21. - Cutting Chain by Nicking

1. Use a grinder and nick the link on both sides (Fig. 21), then secure the link in a vise and break off with a hammer.
2. Use a 7 inch (178mm) minimum diameter by 1/8 inch (3.17mm) thick abrasive wheel (of type recommended by wheel supplier) that will clear adjacent links.
3. Chain may also be cut using a blot cutter (Fig. 22) similar to the H.K. Porter No. 0590MTC with special cutter jaws for cutting hardened chain (1 inch., 25.4mm) long cutting edge).

TESTING

Prior to initial use, all altered or repaired hoists or used hoists that have not been operated for the previous 12 months shall be tested by the user for proper operation.

Test the unit first in the unloaded state and then with a light load of 100 pounds (45kg.) time the number load supporting parts of load chain to be sure it operates properly and the brake holds the load when the lever is released; then test with a load of 125% of rated capacity.

In addition, hoists in which load sustaining parts have been replaced shall be tested with 125% of rated capacity by or under the direction of an appointed person and a written report prepared for record purposes

⚠ WARNING
Cutting chain can produce fly particles.
TO AVOID INJURY:
<ul style="list-style-type: none"> • Wear eye protection • Provide a shield such as a heavy rag over chain to prevent flying particles.

TROUBLESHOOTING CHART

If Tool	Cause may be	Check and Remedy
Is hard to operate in either direction	<ul style="list-style-type: none"> A. Load chain worn or stretched, thus binding between liftwheel and frame. B. Load chain rusty, corroded or clogged with foreign matter such as cement or mud. C. Bushings clogged with matter such as cement and dust. D. Lever head binding on frame. E. Brake parts corroded or clogged with foreign matter. F. Liftwheel pockets clogged with foreign matter or worn excessively causing chain to bind between liftwheel and frame. G. Liftwheel twisted or bent. (1 1/2, 3 & 6-ton only). 	<ul style="list-style-type: none"> A. Check chain, (see page 9) and replace if worn excessively. B. Clean chain by tumble polishing or using a non-acid or non-caustic type solvent. Check chain for gouges, damaged or bent links. Lubricate with Lubriplate[®], Bar and Chain Oil 10-R (Fiske Bros. Refining Co.) or equal lubricant. C. Disassemble and clean liftwheel bushings, pinion shaft bushings, ratchet bushings, and sliding surfaces of ratchet plunger and lever plunger. Any parts worn excessively should be replaced. D. Clean by removing any foreign matter which may be between the head of the lever and the frame section surrounding the brake. E. Disassemble brake and clean thoroughly (by wiping with a cloth - not by washing in a solvent). Replace washers if too gummy, worn or scored. Keep washers and brake surfaces clean and dry. F. Clean out pockets and use if not worn excessively. G. Excessive overload had been applied. Replace damaged parts.
Is hard to operate in down direction	<ul style="list-style-type: none"> A. Brake adjusting nut is too tight. B. Brake parts corroded or clogged with foreign matter. C. Chain binding in frame. 	<ul style="list-style-type: none"> A. See instructions on brake assembly, page 11. B. See item 1E. C. See items 1A and 1B.
Is hard to operate in up direction	<ul style="list-style-type: none"> A. Chain binding in frame. B. Chain twisted- 3 & 6-ton only. C. Overload. 	<ul style="list-style-type: none"> A. See Items 1A and 1B. B. Re-reeve chain or on 3-ton unit, if both chains are twisted, capsize hook block through loop in chain until twists are removed. Caution: Do not operate the Puller in the up direction with twisted chain or chain may become jammed in frame or hook block. C. Reduce load or use correct capacity unit.

ENGLISH

LOAD LIMITER

The Load Limiter is a friction device that is designed and factory calibrated to prevent the lifting of excessive overloads with the 3/4, 1-1/2, 3 and 6 Ton Pullers with Standard Levers. Excessive overload is indicated by lever movement without the corresponding movement of the lower hook block or load when the unit is operated in the "Up" direction. Should overload be evident, immediately switch the trigger to "Down" direction and operate the lever to remove the excess load from the unit. The reduction of the load to rated capacity or less will result in automatic restoration of normal operation.

CAUTION

The Load Limiter is subject to overheating and wear when excessively actuated. For this reason once overloading is detected, the excess load must be removed and normal operation restored without continued undue operation.

The Load Limiter is designed to operate dry without lubrication. Therefore, to assure proper operation, do not apply lubricant to friction surfaces or to adjacent parts of the Load Limiter.

Follow all the instructions and warnings per pages 3 thru 10 when installing, operating, inspecting and maintaining the Puller equipped with the Load Limiter. When disassembling and reassembling the Load Limiter, refer to Fig. 23 and observe the following:

1. To aid in its removal, the hole in the key is threaded. If it is difficult to remove, thread a #10- 24 UNC-2A screw into the hole and pull on the screw to remove the key.
2. Place the spacers in the recess of the outer cone and place the Load Limiter spring on top of the spacers.
3. Be sure to tighten the socket head cap screw to a seating torque of 200 to 250 pound inches (22.6 to 28.2 Nm). If the screw does not remain tight, apply locking compound, such as VC-3 (Nylok-Detroit) to the threads of the screw per the manufacturer's recommendations.

WARNING

The number of spacers used affects the calibration of the load limiter and changing the quantity of spacers will result in the ability to overload the puller or cause the lever to slip at less than rated load.

TO AVOID INJURY:

DO NOT ALTER SPACERS PROVIDED WITH THE UNIT.

Under certain operating conditions, such as applying an overload or removing the load by external means, the brake may become locked. This results in not being able to operate the Puller in the "DN" direction. Should this occur, reapply a load to the lower hook. Place the trigger in the "DN" position and give the lever a sharp pull and then a few additional strokes to lower the load and remove the tension from the Puller.

When testing the unit per page 20, reduce the test load to rated capacity if the lever should slip when attempting to lift the 125% of rated capacity load. After this test, the function of the load limiter should be checked. To do this, attach the lower hook to a load of 180% of rated capacity and operate the unit in the "up" direction. When attempting to lift this load, the lever should slip. After this test, move the trigger to the down position and operate the lever to remove the tension from unit.

Since each Load Limiter is individually calibrated, the components of the device are not sold separately as repair parts. If replacement is necessary order the appropriate Load Limiter Kit (refer to parts list). However, the lever ratchet hub, and lever assembly (as well as the components of the lever assembly) used on a Puller equipped with a Load Limiter can be ordered as repair parts. (Refer to exploded view and parts list on pages 13 -19).

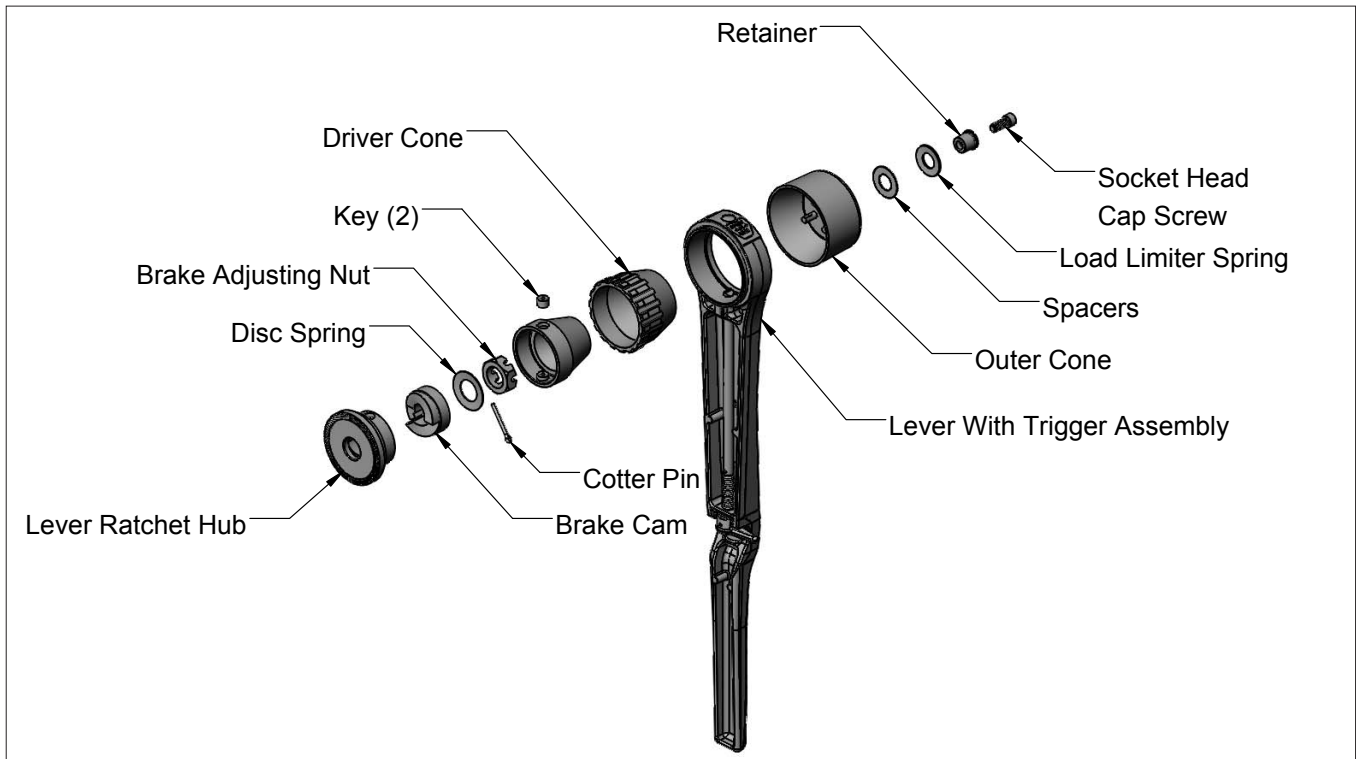

Figure 23. - Load Limiter

WARRANTY

LIMITATION OF WARRANTIES, REMEDIES AND DAMAGES

INDEMNIFICATION AND SAFE OPERATION

Buyer shall comply with and require its employees to comply with directions set forth in instructions and manuals furnished by Seller and shall use and require its employees to follow such instructions and manuals and to use reasonable care in the use and maintenance of the goods. Buyer shall not remove or permit anyone to remove any warning or instruction signs on the goods. In the event of personal injury or damage to property or business arising from the use of the goods, Buyer shall within 48 hours thereafter give Seller written notice of such injury or damage. Buyer shall cooperate with Seller in investigating any such injury or damage and in the defense of any claims arising therefrom.

If Buyer fails to comply with this section or if any injury or damage is caused, in whole or in part, by Buyer's failure to comply with applicable federal or state safety requirements, Buyer shall indemnify and hold Seller harmless against any claims, loss or expense for injury or damage arising from the use of the goods.

CMCO Warranty (HOISTS)

- A. Columbus McKinnon Corporation ("Seller") warrants to the original end user ("Buyer") that: (a) for a period of one (1) year from the date of Seller's delivery of the goods (collectively, the "Goods") to the carrier, the electrical components of the Goods will be free from defects in workmanship and materials; and (b) for the life of the Goods, the mechanical components of the Goods will be free from defects in workmanship and materials.
- B. IN THE EVENT OF ANY BREACH OF SUCH WARRANTY, SELLER'S SOLE OBLIGATION SHALL BE EXCLUSIVELY LIMITED TO, AT THE OPTION OF SELLER, REPAIR OR REPLACEMENT, F.O.B. SELLER'S POINT OF SHIPMENT, OF ANY GOODS THAT SELLER DETERMINES TO HAVE BEEN DEFECTIVE OR, IF SELLER DETERMINES THAT SUCH REPAIR OR REPLACEMENT IS NOT FEASIBLE, TO A REFUND OF THE PURCHASE PRICE UPON RETURN OF THE GOODS TO SELLER. NO CLAIM AGAINST SELLER FOR ANY BREACH OF (i) SUCH WARRANTY WITH RESPECT TO THE ELECTRICAL COMPONENTS OF ANY GOOD SHALL BE VALID OR ENFORCEABLE UNLESS BUYER'S WRITTEN NOTICE THEREOF IS RECEIVED BY SELLER WITHIN ONE (1) YEAR FROM THE DATE OF SELLER'S DELIVERY TO THE CARRIER AND (ii) SUCH WARRANTY WITH RESPECT TO THE MECHANICAL COMPONENTS OF ANY GOOD SHALL BE VALID OR ENFORCEABLE UNLESS BUYER'S WRITTEN NOTICE THEREOF IS RECEIVED BY SELLER WITHIN ONE (1) YEAR FROM THE DATE THE DATE ANY ALLEGED CLAIM ACCRUES. EXCEPT FOR THE WARRANTY SET FORTH ABOVE, SELLER MAKES NO OTHER WARRANTIES WITH RESPECT TO THE GOODS, WHETHER EXPRESSED OR IMPLIED, INCLUDING ANY WARRANTIES OF MERCHANTABILITY, FITNESS FOR A PARTICULAR PURPOSE, QUALITY AND/OR THOSE ARISING BY STATUTE OR OTHERWISE BY LAW OR FROM ANY COURSE OF DEALING OR USE OF TRADE, ALL OF WHICH ARE HEREBY EXPRESSLY DISCLAIMED.

C. IN NO EVENT SHALL SELLER BE LIABLE TO BUYER OR ANY THIRD PARTY WITH RESPECT TO ANY GOOD, WHETHER IN CONTRACT, TORT OR OTHER THEORY OF LAW, FOR LOSS OF PROFITS OR LOSS OF USE, OR FOR ANY INCIDENTAL, CONSEQUENTIAL, SPECIAL, DIRECT OR INDIRECT DAMAGES, HOWSOEVER CAUSED. SELLER'S MAXIMUM LIABILITY TO BUYER WITH RESPECT TO THE GOODS SHALL IN NO EVENT EXCEED THE PRICE PAID BY BUYER FOR THE GOODS THAT ARE THE SUBJECT OF THE APPLICABLE CLAIM.

D. Seller shall not be liable for any damage, injury or loss arising out of the use of the Goods if, prior to such damage, injury or loss, such Goods are: (1) damaged or misused following Seller's delivery to the carrier; (2) not maintained, inspected, or used in compliance with applicable law and Seller's written instructions and recommendations; or (3) installed, repaired, altered or modified (a) with any part or accessory other than those supplied by Seller or (b) without compliance with such laws, instructions or recommendations.

E. This warranty is limited and provided only to the original end user. **Each Good must be registered within sixty (60) days of receipt of each product to establish eligibility.** Please register at www.cmworks.com/hoist-warranty-registration or submit registration card via US mail.

F. Any action against Seller for breach of warranty, negligence or otherwise in connection with the electrical components of any Good must be commenced by Buyer within one (1) year after: (a) the date any alleged claim accrues; or (b) the date of delivery of the Goods to Buyer, whichever is earlier. Any action against Seller for breach of warranty, negligence or otherwise in connection with the mechanical components of any Good must be commenced by Buyer within one (1) year after the date any alleged claim accrues.

G. This warranty is contingent upon Buyer's proper maintenance and care of the Goods, and does not extend to normal wear and tear. Seller reserves the right, at its option, to void this warranty in the event of Buyer's use with the Goods of parts or accessories other than those supplied by Seller.

WARNING

Alterations or modifications of equipment and use of non-factory repair parts can lead to dangerous operation and injury.

TO AVOID INJURY:

- Do not alter or modify equipment.
- Do use only factory replacement parts.



FAMILY OF BRANDS



Distributed by Tri-State Equipment Company Inc.
sales@tsoverheadcrane.com
www.tsoverheadcrane.com
Tel: (314) 869-7200